

MaxAW05-1100

Full Servo Robot
IMM RANGE 200 – 300 Ton

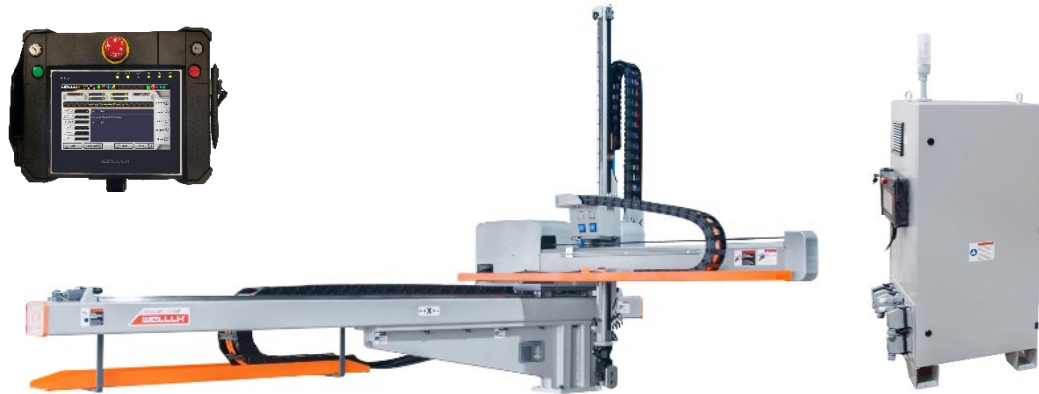

MaxAW05-1100	Standard		Metric	
Movement	Vertical Arm	Servo Telescoping	Servo Telescoping	Vertical Arm
IMM Range	US Tons	200 - 300	1779 - 2669	kN
Max Payload	lbs	11.02	5	kg
Vertical Stroke	in	43.31	1100	mm
Single Arm Strip	in	47.24	1200	mm
Traverse	in	70.87	1800	mm
Gripper Angle	Degree (°)	90	90	Degree (°)
Robot Weight	lbs	816	370	kg
Drive System	Drive	AC Servo Motor	AC Servo Motor	Drive
Working Air Pressure	psi	71.12 ~ 113.81	5 ~ 8	kg/cm ²
Air Consumption	Fluid oz	33.81	1	NI/cycle
Max Amperage	Amps	8.9	8.9	Amps
Power Supply	Power Supply	480VAC - 3 Phase - 60 Hz	480VAC - 3 Phase - 60 Hz	Power Supply



Rev: 1 - 03312021

508-792-4305 | absoluterobot.com

MaxAW05-1100

Full Servo Robot
IMM RANGE 200 – 300 Ton



STANDARD FEATURES:

- Riser/Adapter Plate
- 2 Vacuum Circuits
- 2 Gripper Circuits
- 20 Spare Input/Output signals
- Pneumatic “Flip” C-Axis
- 3-Axis Synchronized Movement
- Absolute Encoders (faster robot programming)
- Advanced Vibration Dampening
- Supervisory Safety Circuit (STO)
- Compact Floor Mounted Electrical Cabinet for Easy Maintenance
- Fully unlocked robot pendant
- Large Mold Storage Capacity
- Programs Stored in Cabinet, Not Pendant (data not lost if pendant damaged)
- 26 ft (8 m) Long Pendant Cable for Maneuverability While Programming
- Advanced Mold & Vertical Arm Protection
- Quick Change Universal Mounting Plate on Vertical Arm
- Flexible Orientation Swap for Operator or Non-Operator Part Discharge
- Euromap Adapter for Both 12 & 67 Molding Machines
- Telescoping Vertical Arm for Low Height Clearance



OPTIONS:

- Additional Vacuum Circuit with Detection*
- Additional Gripper Circuit*
- Expanded I/O*
- Pneumatic Wrist Rotate*
- Extended Traverse
- Beam Mounted Electrical Cabinet
- Dual-Arm
- Secondary Vertical Arm for 3-Plate Molds
- In-Line Take Out (Traverse Over Clamp)
- Extended Pendant Cable
- Custom End-Of-Arm-Tooling
- Downstream Equipment (Guarding, Conveyors, Labeling, Packaging, etc.)



*Can be added to an existing in-stock robot



Rev: 1 - 03312021

508-792-4305 | absoluterobot.com

MaxAW05-1100

Full Servo Robot
IMM RANGE 200 – 300 Ton

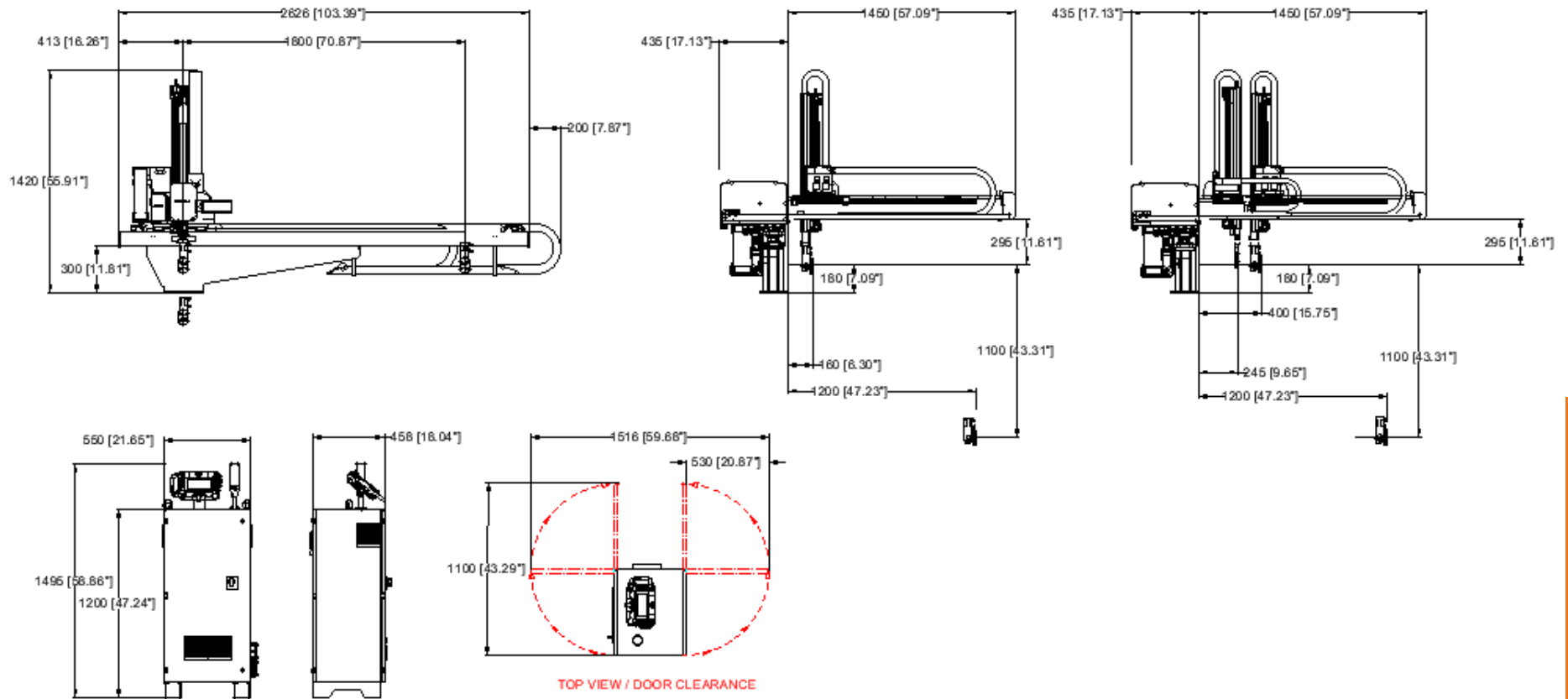

Specifications are subject to change